



# N-Channel JFET High Frequency Amplifier

T-31-25

2N3821 / 2N3822

**FEATURES**

- Low Capacitance
- Up to 6500 $\mu$ s Transconductance

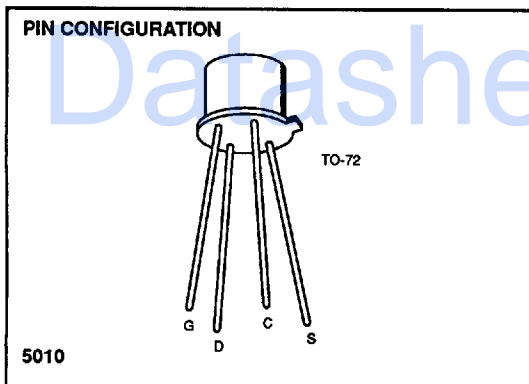

**ABSOLUTE MAXIMUM RATINGS**  
( $T_A = 25^\circ\text{C}$  unless otherwise noted)

Gate-Source Voltage	..... -50V
Gate-Drain Voltage	..... -50V
Gate Current	..... 10mA
Storage Temperature Range	..... $-65^\circ\text{C}$ to $+200^\circ\text{C}$
Operating Temperature Range	..... $-55^\circ\text{C}$ to $+175^\circ\text{C}$
Lead Temperature (Soldering, 10sec)	..... $+300^\circ\text{C}$
Power Dissipation	..... 300mW
Derate above $25^\circ\text{C}$	..... 2.0mW/ $^\circ\text{C}$

**NOTE:** Stresses above those listed under "Absolute Maximum Ratings" may cause permanent damage to the device. These are stress ratings only and functional operation of the device at these or any other conditions above those indicated in the operational sections of the specifications is not implied. Exposure to absolute maximum rating conditions for extended periods may affect device reliability.

**ORDERING INFORMATION**

Part	Package	Temperature Range
2N3821	Hermetic TO-72	$-55^\circ\text{C}$ to $+175^\circ\text{C}$
X2N3821	Sorted Chips in Carriers	$-55^\circ\text{C}$ to $+175^\circ\text{C}$
2N3822	Hermetic TO-72	$-55^\circ\text{C}$ to $+175^\circ\text{C}$
X2N3822	Sorted Chips in Carriers	$-55^\circ\text{C}$ to $+175^\circ\text{C}$

**ELECTRICAL CHARACTERISTICS** ( $T_A = 25^\circ\text{C}$  unless otherwise specified)

SYMBOL	PARAMETER	2N3821		2N3822		UNITS	TEST CONDITIONS
		MIN	MAX	MIN	MAX		
$I_{gss}$	Gate Reverse Current		-0.1		-0.1	nA	$V_{GS} = -30V, V_{DS} = 0$ $T_A = 150^\circ\text{C}$
			-0.1		-0.1	$\mu\text{A}$	
$BV_{GSS}$	Gate-Source Breakdown Voltage	-50		-50		V	$I_G = -1\mu\text{A}, V_{DS} = 0$
$V_{GS(off)}$	Gate-Source Cutoff Voltage		-4		-6		$V_{DS} = 15V, I_D = 0.5\text{nA}$
$V_{GS}$	Gate-Source Voltage	-0.5	-2				$V_{DS} = 15V, I_D = 50\mu\text{A}$
				-1	-4		$V_{DS} = 15V, I_D = 200\mu\text{A}$
$I_{DSS}$	Saturation Drain Current (Note 1)	0.5	2.5	2	10	mA	$V_{DS} = 15V, V_{GS} = 0$

2N3821 / 2N3822

2N3821 / 2N3822



T-31-25

ELECTRICAL CHARACTERISTICS (Continued) (T<sub>A</sub> = 25°C unless otherwise specified)

SYMBOL	PARAMETER	2N3821		2N3822		UNITS	TEST CONDITIONS	
		MIN	MAX	MIN	MAX			
$g_{fs}$	Common-Source Forward Transconductance (Note 1)	1500	4500	3000	6500	μs	$V_{DS} = 15V, V_{GS} = 0$	f = 1kHz
$ y_{fs} $	Common-Source Forward Transadmittance (Note 2)	1500		3000				f = 100MHz
$g_{os}$	Common-Source Output Conductance (Note 1)		10		20			f = 1kHz
$C_{iss}$	Common-Source Input Capacitance (Note 2)		6		6	pF		f = 1MHz
$C_{rss}$	Common-Source Reverse Transfer Capacitance (Note 2)		3		3			
NF	Noise Figure (Note 2)		5		5	dB	$V_{DS} = 15V, V_{GS} = 0,$ $R_{gen} = 1meg, BW = 5Hz$	f = 10Hz
$\bar{e}_n$	Equivalent Input Noise Voltage (Note 2)		200		200			

- NOTES: 1. These parameters are measured during a 2ms interval 100ms after DC power is applied.  
 2. For design reference only, not 100% tested.