

7 CIRCUIT DARLINGTON TRANSISTOR ARRAY

FEATURES

- Output Current : 500mA Max.
- High Sustaining Voltage Outputs : 50V Min.
- Output Clamp Diodes
- Inputs Compatible With Various Types of Logic.
- PKG Type APV : DIP-16Pin, AFV : FLP-16Pin

TYPE	INPUT RESISTOR	DESIGNATION
KID65001APV/AFV	No (External)	General Purpose
KID65002APV/AFV	Zener Diode 7V+10.5k Ω	14~25V P-MOS
KID65003APV/AFV	2.7k Ω	TTL, 5V C-MOS
KID65004APV/AFV	10.5k Ω	6~15V P-MOS, C-MOS

DESCRIPTION:

The KID65001APV/AFV Series are high-voltage, high-current darlington transistor array comprised of seven NPN darlington pairs. All units feature internal clamp diodes for switching inductive loads.

MAXIMUM RATINGS (Ta=25°C, unless otherwise noted)

CHARACTERISTIC		SYMBOL	RATING	UNIT
Output Sustaining Voltage		$V_{CE(SUS)}$	50	V
Output Current		I_{OUT}	500	mA
Input Voltage		V_{IN}^*	-0.5 ~ +30	V
Input Current		I_{IN}^{**}	25	mA
Clamp Diode	Reverse Voltage	V_R	50	V
	Forward Current	I_F	500	mA
GND Terminal Current		I_{GND}	2.8	A
Power Dissipation	APV	P_D	1.47	W
	AFV		0.54	W
Operating Temperature		T_{opr}	-40 ~ 85	°C
Storage Temperature		T_{stg}	-55 ~ 150	°C

*Except KID65001APV/AFV, **Only KID65001APV/AFV

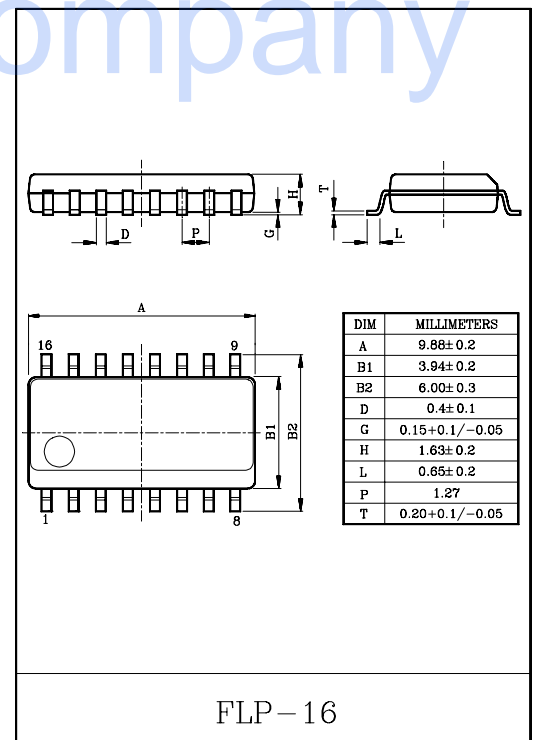
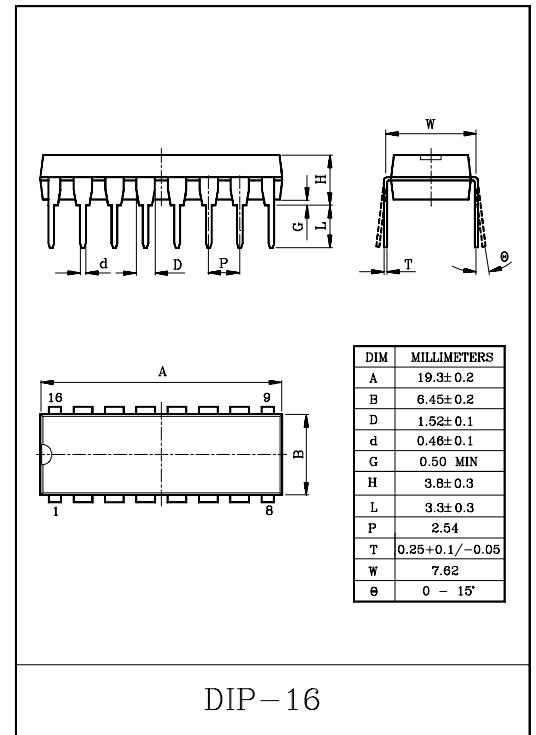

KID65001APV/AFV ~ KID65004APV/AFV

PIN CONNECTION (TOP VIEW)

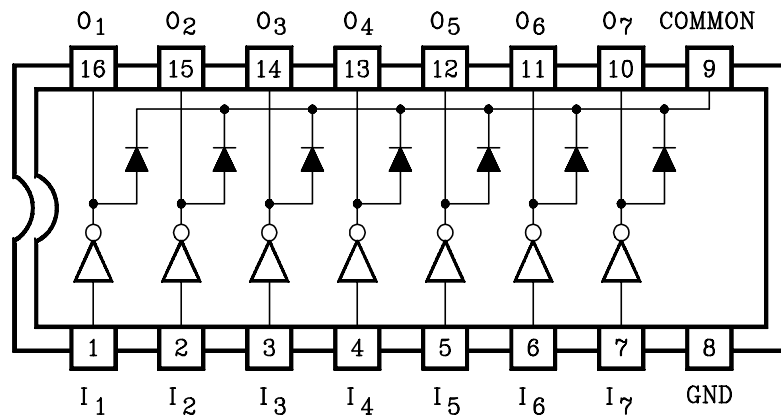

SCHEMATICS (EACH DRIVER)

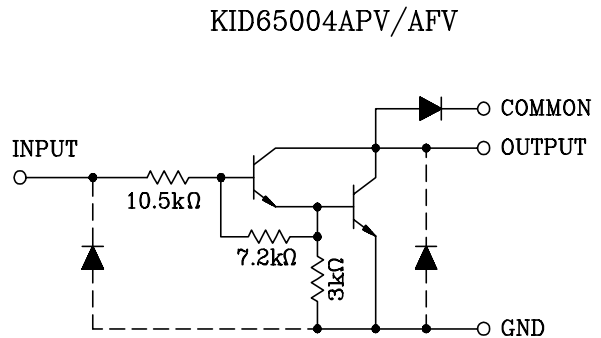
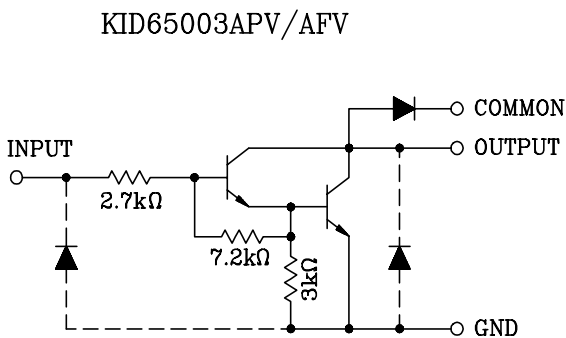
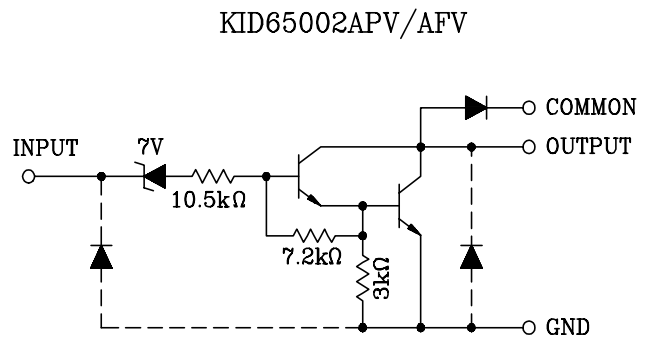
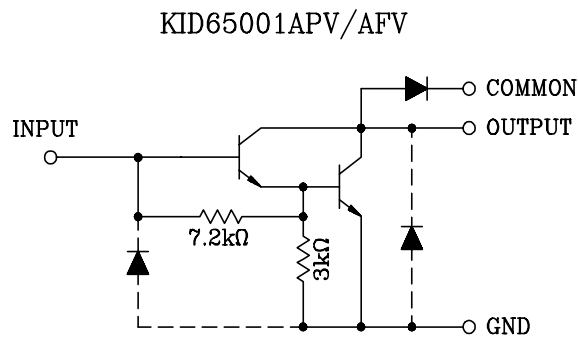

KID65001APV/AFV ~ KID65004APV/AFV

RECOMMENDED OPERATING CONDITIONS (Ta=-40~85°C)

CHARACTERISTIC		SYMBOL	CONDITION	MIN.	TYP.	MAX.	UNIT
Output Sustaining Voltage		V _{CE(SUS)}		0	-	50	V
Output Current		I _{OUT}	T _{PW} =25ms, DF=10%, 7 Circuits	0	-	400	mA
			T _{PW} =25ms, DF=30%, 7 Circuits	0	-	200	
Input Voltage		V _{IN}	Except KID65001APV/AFV	0	-	30	V
Input Current		I _{IN}	Only KID65001APV/AFV	0	-	5	mA
Clamp Diode Reverse Voltage		V _R		-	-	50	V
Clamp Diode Forward Current		I _F		-	-	400	mA
Power Dissipation	APV	P _D	Ta=Topr(max)	-	-	0.52	W
	AFV			-	-	0.32	

ELECTRICAL CHARACTERISTICS (Ta=25°C, unless otherwise noted)

CHARACTERISTICS		SYMBOL	TEST CIRCUIT	TEST CONDITION	MIN.	TYP.	MAX.	UNIT
Output Leak Current		I _{CEX}	1	V _{CE} =50V, Ta=25°C	-	-	50	μA
				V _{CE} =50V, Ta=85°C	-	-	100	
	KID65002APV/AFV			V _{CE} =50V, V _{IN} =6V	-	-	500	
	KID65004APV/AFV			V _{CE} =50V, V _{IN} =1V	-	-	500	
Collector-Emitter Saturation Voltage		V _{CE(sat)}	2	I _{OUT} =350mA, I _{IN} =500μA	-	1.3	1.6	V
				I _{OUT} =200mA, I _{IN} =350μA	-	1.1	1.3	
				I _{OUT} =100mA, I _{IN} =250μA	-	0.9	1.1	
Input Current	KID65002APV/AFV	I _{IN(ON)}	3	V _{IN} =17V	-	0.82	1.25	mA
	KID65003APV/AFV			V _{IN} =3.85V	-	0.93	1.35	
	KID65004APV/AFV			V _{IN} =5V	-	0.35	0.5	
				V _{IN} =12V	-	1.0	1.45	
	I _{IN(OFF)}	4	I _{OUT} =500μA, Ta=85°C	50	65	-	μA	
Input Voltage	KID65002APV/AFV	V _{IN(ON)}	5	V _{CE} =2V, I _{OUT} =300mA	-	-	13	V
				V _{CE} =2V, I _{OUT} =200mA	-	-	2.4	
	KID65003APV/AFV			V _{CE} =2V, I _{OUT} =250mA	-	-	2.7	
				V _{CE} =2V, I _{OUT} =300mA	-	-	3.0	
	KID65004APV/AFV			V _{CE} =2V, I _{OUT} =125mA	-	-	5.0	
				V _{CE} =2V, I _{OUT} =200mA	-	-	6.0	
				V _{CE} =2V, I _{OUT} =275mA	-	-	7.0	
				V _{CE} =2V, I _{OUT} =350mA	-	-	8.0	
DC Current Transfer Ratio		h _{FE}	2	V _{CE} =2V, I _{OUT} =350mA	1000	-	-	
Clamp Diode Reverse Current		I _R	6	V _R =50V, Ta=25°C	-	-	50	μA
				V _R =50V, Ta=85°C	-	-	100	
Clamp Diode Forward Voltage		V _F	7	I _F =350mA	-	-	2.0	V
Input Capacitance		C _{IN}			-	15	-	pF
Turn-ON Delay		t _{ON}	8	V _{OUT} =50V, R _L =163Ω C _L =15pF	-	0.1	-	μS
Turn-OFF Delay		t _{OFF}			-	0.2	-	

TEST CIRCUIT

1. I_{CEX}

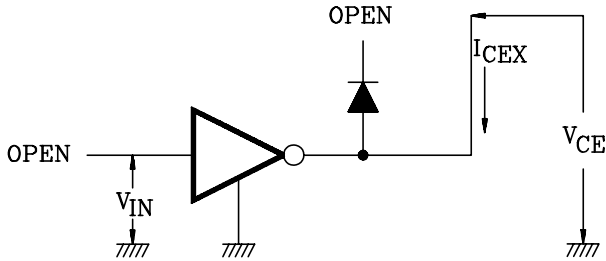

2. $V_{CE(sat)}$, h_{FE}

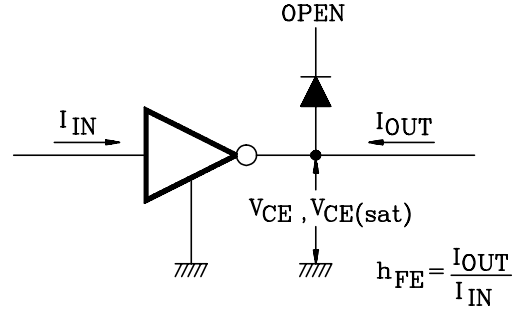

3. $I_{IN(ON)}$

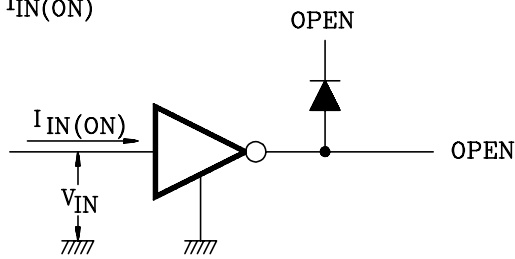

4. $I_{IN(OFF)}$

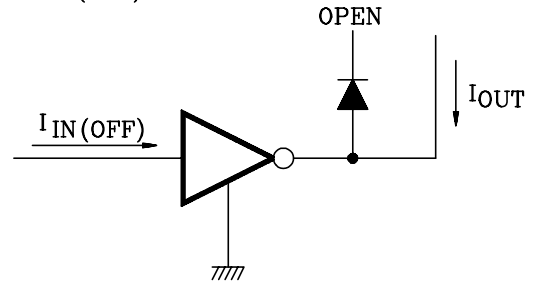

5. $V_{IN(ON)}$

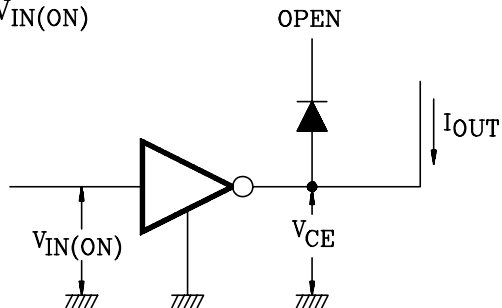

6. I_R

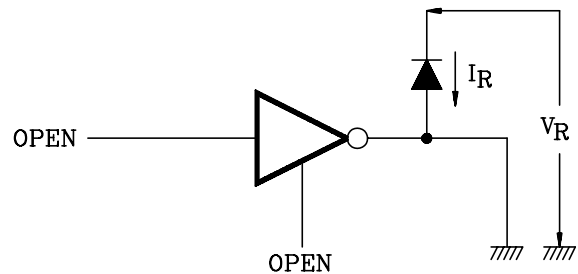

7. V_F

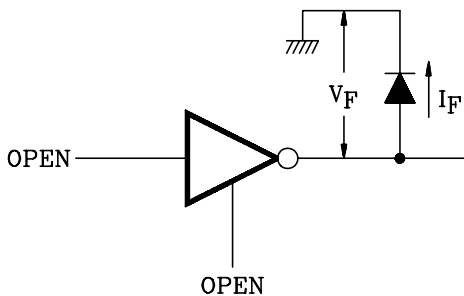

8. t_{ON}, t_{OFF}

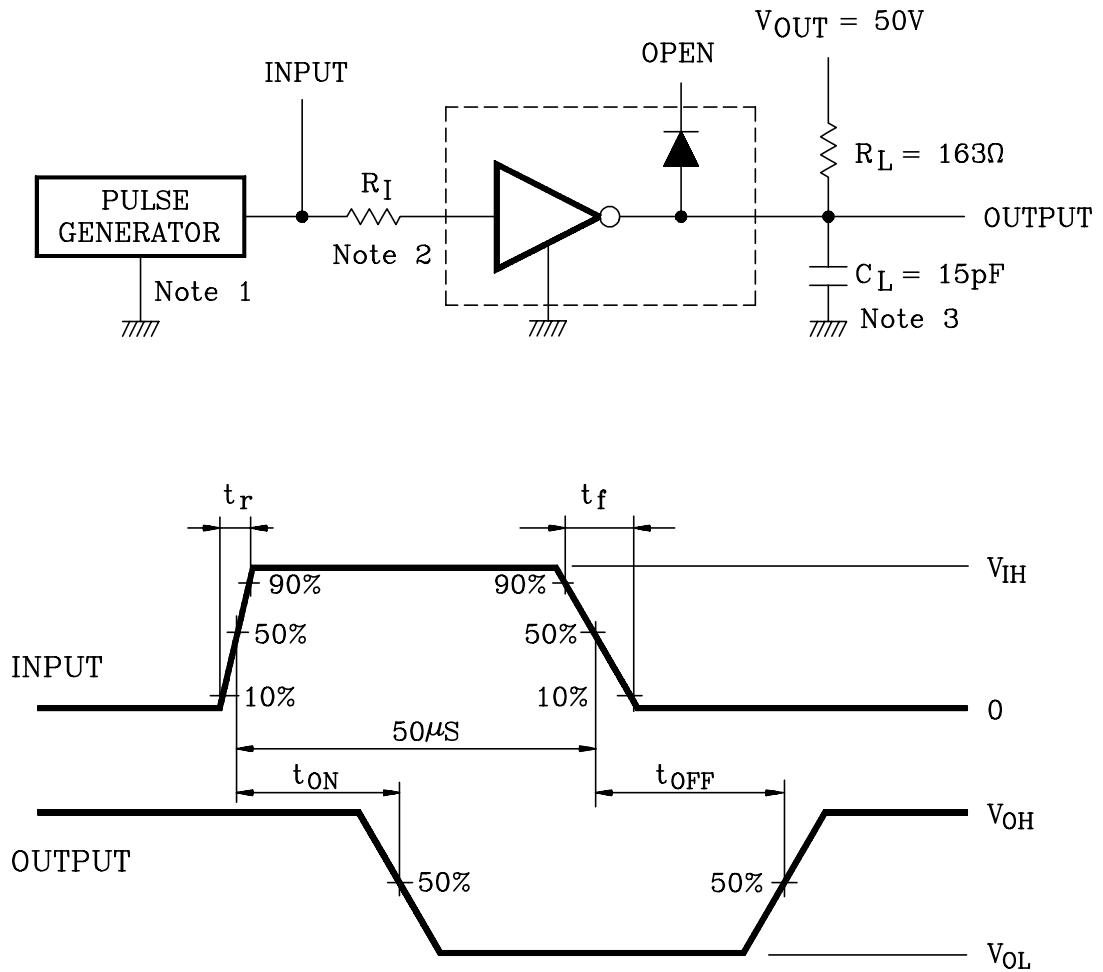

Notes : 1. Pulse Width $50\mu\text{S}$, Duty Cycle 10%
Output Impedance 50Ω , $t_r \leq 5\text{ns}$, $t_f \leq 10\text{ns}$

2. See below

Input Conditions

Type Number	R_I	V_{IH}
KID65001APV/AFV	$2.7\text{k}\Omega$	3V
KID65002APV/AFV	0	13V
KID65003APV/AFV	0	3V
KID65004APV/AFV	0	8V

3. C_L includes probe and jig capacitance.

KID65001APV/AFV ~ KID65004APV/AFV

KID65002APV/AFV

$I_{IN} - V_{IN}$

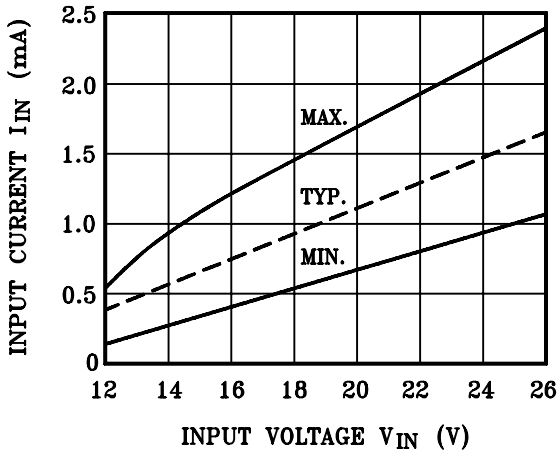

KID65003APV/AFV

$I_{IN} - V_{IN}$

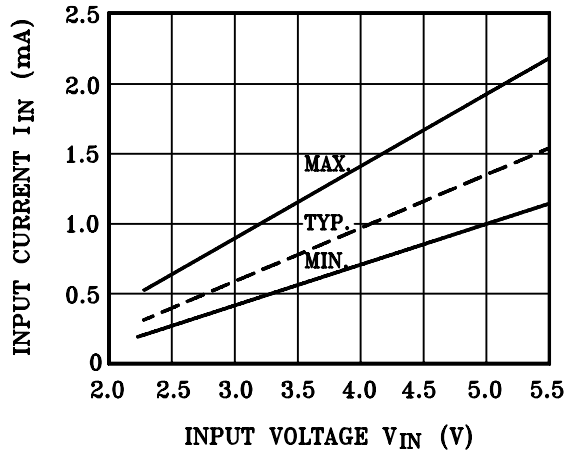

KID65004APV/AFV

$I_{IN} - V_{IN}$

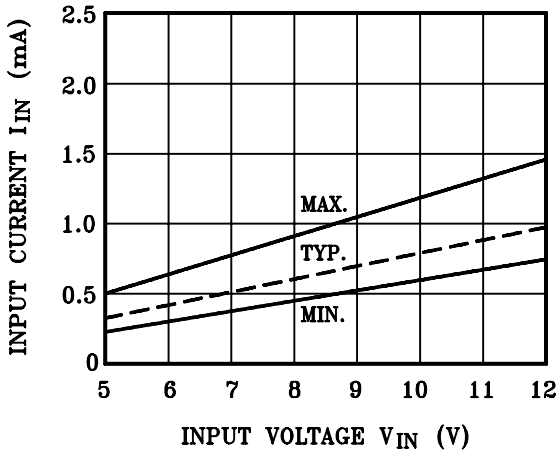

$I_{OUT} - V_{CE(sat)}$

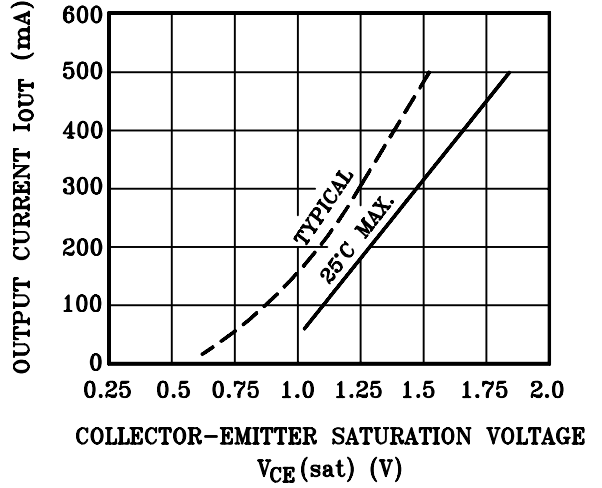

$I_{OUT} - \text{DUTY CYCLE}$

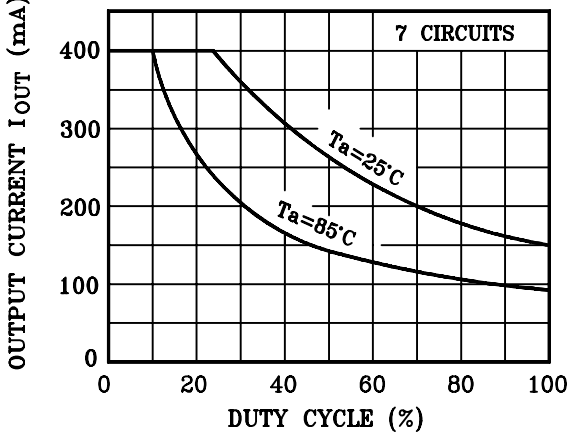

$P_D - T_a$

