

DUAL COMPARATOR

FEATURES

- Be Possible to Operate at the Wide Range Single or Two Supply Voltage.
- Low Supply Current : $I_{CC}=0.6mA(Typ.)$.
- Low Input Offset Voltage : $V_{IO}=1mV(Typ.)$.
- Wide Common Mode Input Voltage : $0V_{DC}$ to $V_{CC}-1.5V_{DC}$.
- Output is Compatible with TTL, DTL, MOS and C-MOS.
- Output is Open Collector and Wired-OR Possible.

PIN CONNECTION (TOP VIEW)

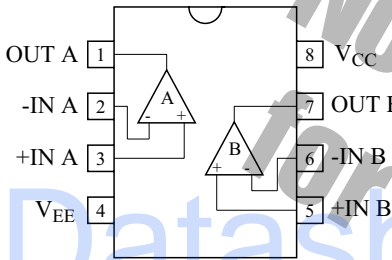

MARKING

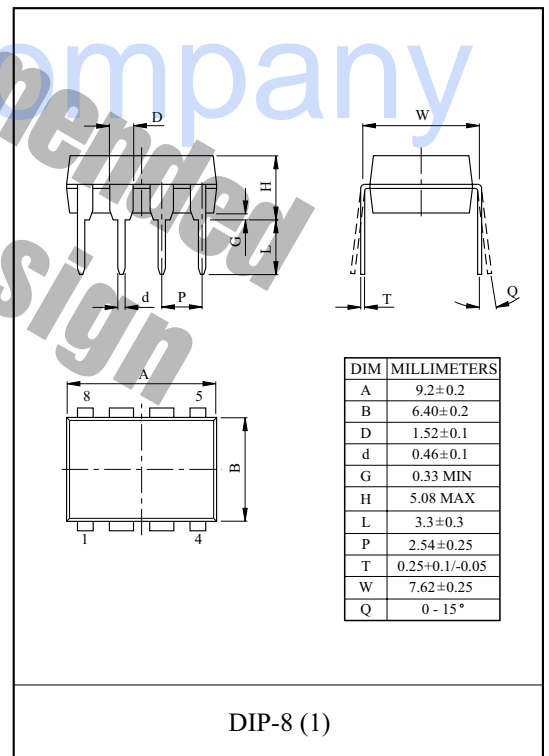
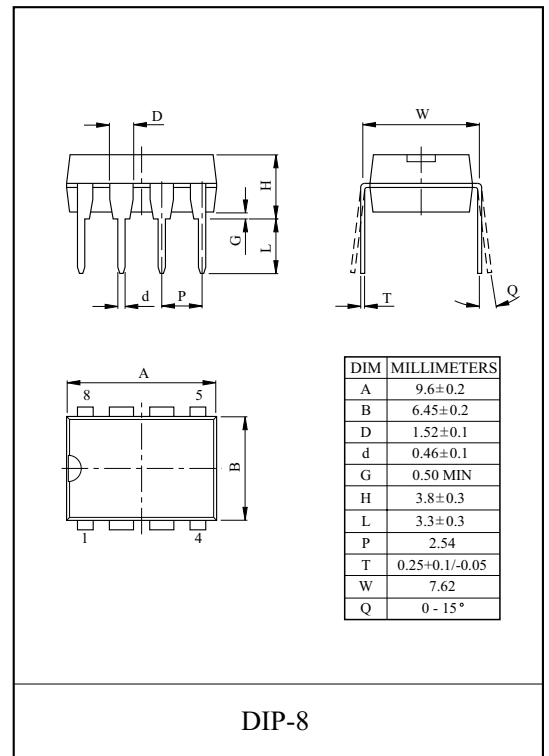
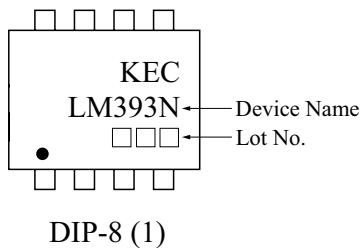
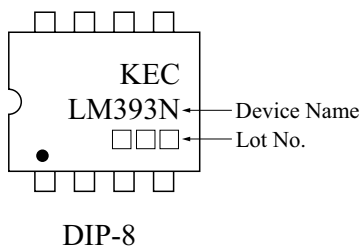

LM393N

EQUIVALENT CIRCUIT

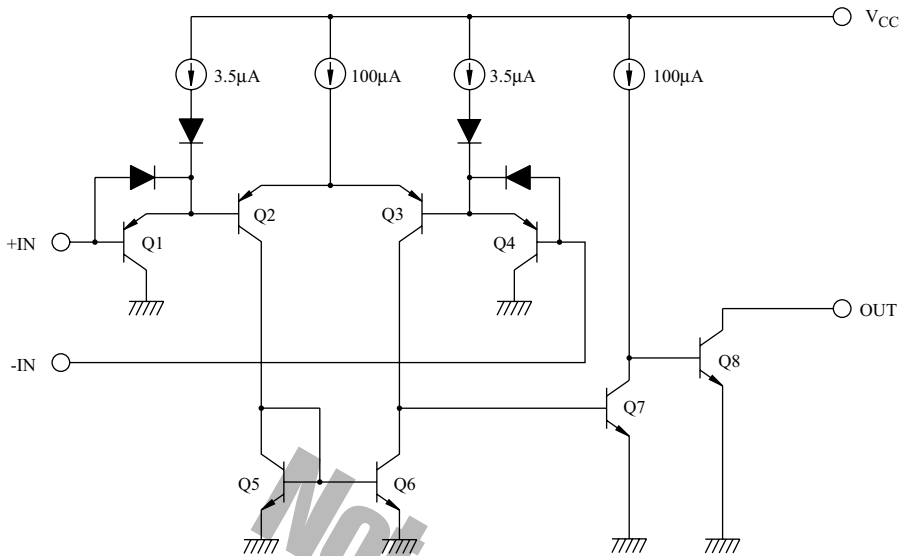

MAXIMUM RATINGS (Ta=25 °C)

CHARACTERISTIC	SYMBOL	RATING	UNIT
Supply Voltage	V_{CC}	$\pm 18, 36$	V
Differential Input Voltage	DV_{IN}	$\pm 18, 36$	V
Common Mode Input Voltage	CMV_{IN}	$-0.3 V_{CC}$	V
Power Dissipation	LM393N P_D	500	mW
Operating Temperature	T_{opr}	0 70	
Storage Temperature	T_{stg}	-55 125	

ELECTRICAL CHARACTERISTICS (V_{CC}=5V, V_{EE}=GND, Ta=25 °C)

CHARACTERISTIC	SYMBOL	TEST CONDITION	MIN.	TYP.	MAX.	UNIT
Input Offset Voltage	V_{IO}	$V_O=1.4V$	-	1	5	mV
Input Offset Current	I_{IO}	-	-	5	50	nA
Input Bias Current	I_I	-	-	65	250	nA
Common Mode Input Voltage	CMV_{IN}	-	0	-	$V_{CC}-1.5$	V
Voltage Gain	G_V	$R_L=15k$	-	200	-	V/mV
Supply Current	I_{CC}	No load	-	0.6	2.5	mA
Sink Current	I_{sink}	+IN=0V, -IN=1V, $V_{OL}=1.5V$	6	18	-	mA
Output Voltage ("L" Level)	V_{OL}	+IN=0V, -IN=1V, $I_{sink}=4mA$	-	160	400	mV
Output Leak Current	I_{LEAK}	+IN=1V, -IN=0V, $V_O=5V$	-	0.1	-	nA
Response Time	t_{rsp}	$R_L=5.1k, C_L=15pF$	-	1.4	-	μs

LM393N

$V_{CC} - I_{CC}$

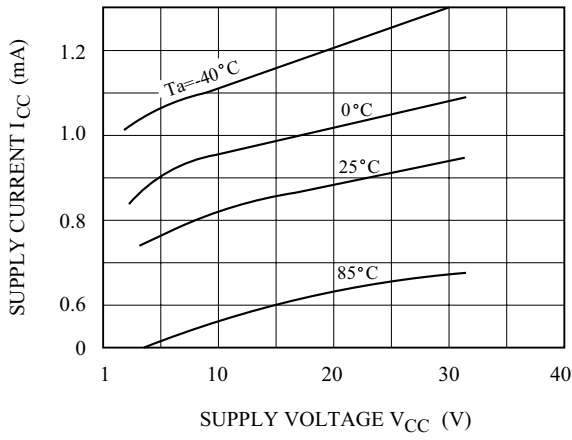

$V_{CC} - I_I$

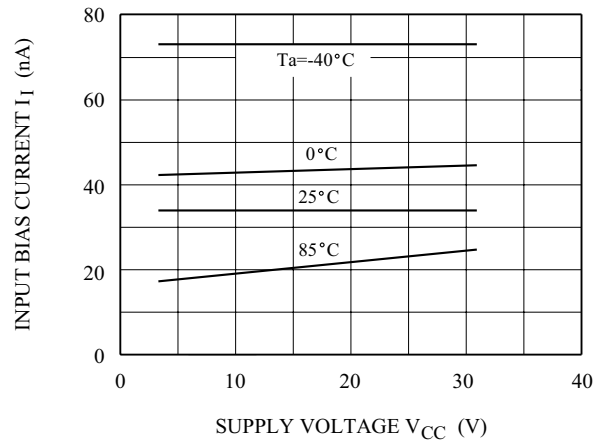

$V_{OL} - I_{SINK}$

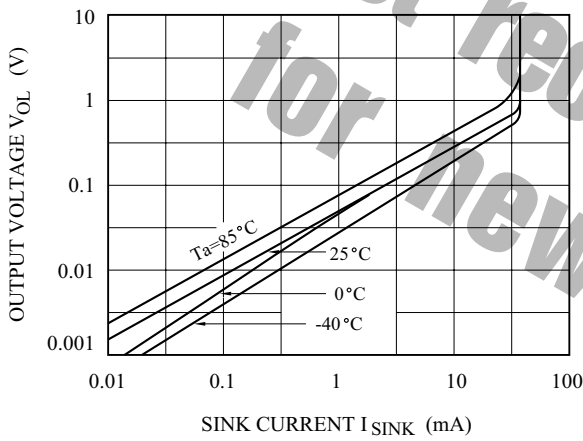

$V_{IN}, V_{OUT} - t_{rsp}$

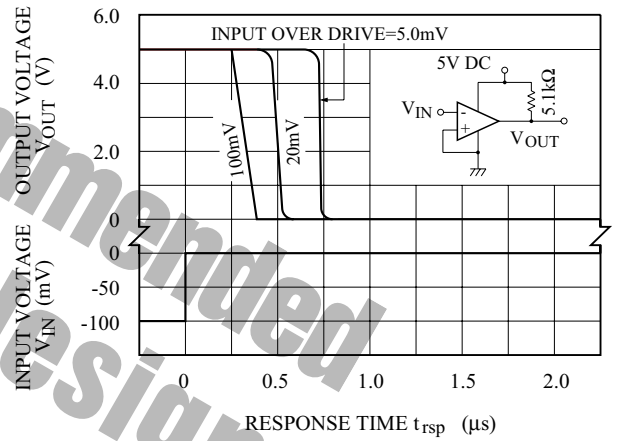

$V_{IN}, V_{OUT} - t_{rsp}$

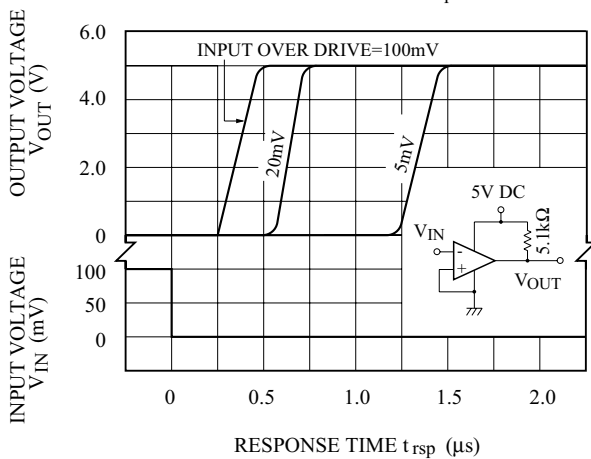

$P_D - T_a$

