



DESCRIPTION

The ES1938 PCI AudioDrive® solution implements a single-chip PCI audio solution, providing high-quality audio processing while maintaining full legacy DOS game compatibility. With a dynamic range over 80 dB, the ES1938 complies with the Microsoft® PC 98 / PC 99 specifications and meets WHQL audio requirements. The ES1938 forms a complete audio subsystem on a single chip for motherboard platforms.

The ES1938 incorporates a microcontroller, ESFM™ music synthesizer, 16-bit stereo wave ADC and DAC, 16-bit stereo music DAC, MPU-401 UART mode serial port, dual game port, hardware master volume control, a serial port interface to external wavetable music synthesizer, DMA control logic with FIFO, and PCI bus interface logic. There are three stereo inputs (typically, line-in, CD audio, and auxiliary line) and a mono microphone input.

The ES1938 provides a serial EEPROM interface for ease of programming the Subsystem ID and Subsystem Vendor ID.

The ES1938 integrates the ESS Technology field-proven hardware design for DOS game compatibility with hardware FM synthesis (ESFM synthesis) and three methods for legacy audio control interface: PC/PCI, Distributed DMA, and Transparent DMA. Transparent DMA requires no sideband signals from PC core logic chipsets in addition to the standard PCI 2.2 bus. Transparent DMA (TDMA) is compatible with the Intel® Pentium®, Pentium II®, and Celeron™ chipsets, as well as standard PCI add-in cards.

The ES1938 can record, compress, and play back voice, sound, and music with built-in mixer controls. It supports stereo full-duplex operation for simultaneous record and playback. The ESFM synthesizer has extended capabilities within native mode operation providing superior sound and power-down capabilities.

The ES1938 also incorporates Spatializer® VBX™ technology, provided by Desper Products, Inc., a subsidiary of Spatializer Audio Laboratories, Inc. This processor expands the stereo sound field emitted by two speakers to create a resonant 3D sound environment.

The ES1938 is compliant with Advanced Power Management (APM) 1.2, Advanced Configuration and Power Interface (ACPI) 1.0, and PCI Power Management Interface (PPMI) 1.0.

It is available in an industry-standard 100-pin low-profile quad flat pack (LQFP) package.

FEATURES

- Single, high-performance, mixed-signal, 16-bit stereo VLSI chip
- PCI parallel bus interface, revision 2.2
- Full native DOS games compatibility, via three technologies:
 - TDMA
 - DDMA
 - PC/PCI
- High-quality ESFM music synthesizer
- Dynamic range (SNR) over 80 dB
- Integrated Spatializer 3D VBX stereo audio effects processor provided by Desper Products, Inc., a subsidiary of Spatializer Audio Laboratories, Inc.

Record and Playback Features

- Record, compress, and play back voice, sound, and music
- 16-bit stereo ADC and DAC
- Programmable independent sample rates from 6 kHz up to 48 kHz for record and playback
- Full-duplex operation for simultaneous record and playback
- 2-wire hardware volume control for up, down, and mute

Inputs and Outputs

- Stereo inputs for line-in, auxiliary A (CD audio), and auxiliary B, and a mono input for microphone
- MPU-401 (UART mode) interface for wavetable synthesizers and MIDI devices
- Integrated dual game port
- Separate mono input (MONO_IN) and mono output (MONO_OUT) for speakerphone

Mixer Features

- 7-channel mixer with stereo inputs for line, CD audio, auxiliary line, music synthesizer, digital audio (wave files), and mono inputs for microphone and speakerphone
- Programmable 6-bit logarithmic master volume control

Power

- Advanced power management meets APM 1.2, ACPI 1.0, and PPMI 1.0 standards

Compatibility

- Supports PC games and applications for SoundBlaster™ and SoundBlaster Pro™
- Meets PC 98 / PC 99 and WHQL specifications

BLOCK DIAGRAM

Figure 1 shows the ES1938 block diagram.

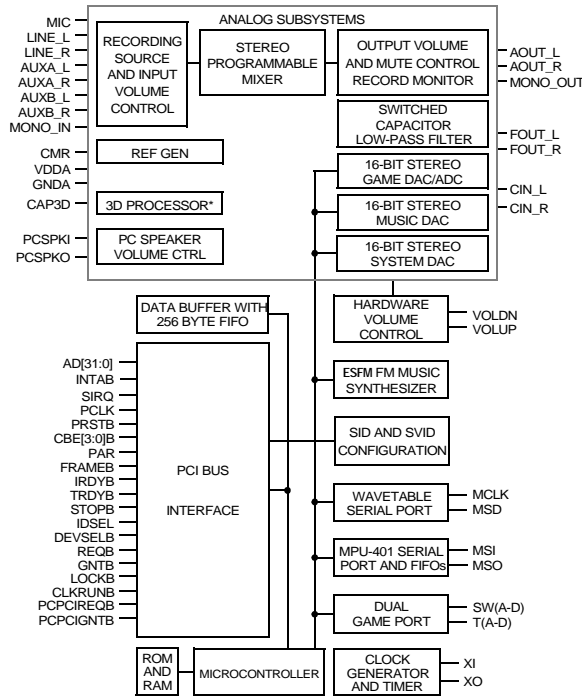

* 3D Processor uses SpatializerV/BX 3D technology provided by Desper Products, Inc. a subsidiary of Spatializer Audio Laboratories, Inc.

Figure 1 ES1938 Block Diagram

PINOUT

Figure 2 shows the ES1938 pinout diagram.

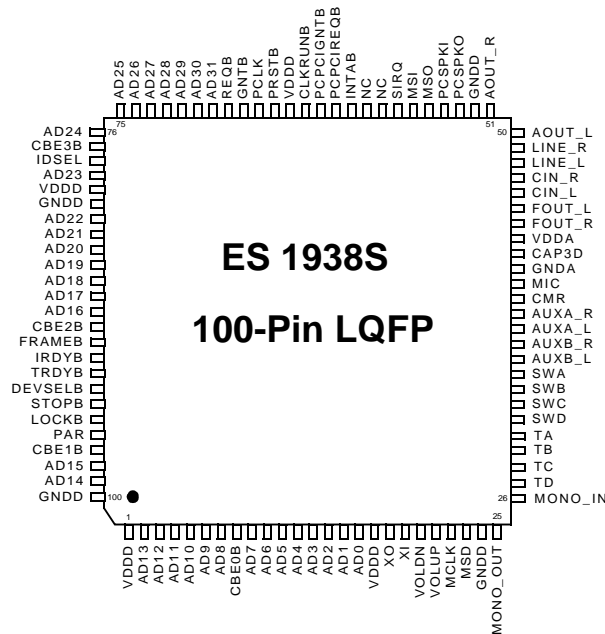

Figure 2 ES1938 Pinout Diagram

ES1938 PIN DESCRIPTIONS

Table 1 lists the ES1938 pin descriptions.

Table 1 ES1938 Pin Descriptions

Names	Pin Numbers	I/O	Descriptions
VDDD	1, 17, 64, 80	I	Digital supply voltage (5V±5%).
AD[31:0]	2:7, 9:16, 69:76, 79, 82:88, 98:99	I/O	Address and data lines from the PCI bus.
CBE[3:0]B	8, 77, 89, 97	I/O	PCI command/byte enable.
XO	18	O	Oscillator output. Connect to external 14.318-MHz crystal.
XI	19	I	Oscillator/external clock input. Connect to external 14.318-MHz crystal or clock source (must be CMOS levels).
VOLDN	20	I	Active-low volume decrease button input with internal pull-up.
VOLUP	21	I	Active-low volume increase button input with internal pull-up.
MCLK	22	I	Input with internal pull-down. Music serial clock from external wavetable music synthesizer.
MSD	23	I	Input with internal pull-down. Music serial data from external wavetable music synthesizer.
GNDD	24, 52, 81, 100	I	Digital ground.
MONO_OUT	25	O	Mono output with source select and volume control (including mute). This pin can drive an external 5k AC load.
MONO_IN	26	I	Mono input to mixer and ADC. This pin has an internal pull-up to CMR.
T(A-D)	30:27	I/O	Joystick timer. These pins connect to the X-Y positioning variable resistors for the two joysticks.
SW(A-D)	31:34	I	Active-low joystick switch setting inputs. These SW pins have an internal pull-up resistor.
AUXB_L, AUXB_R	35, 36	I	Auxiliary B inputs, left and right. AUXB_L and AUXB_R have internal pull-up resistors to CMR.
AUXA_L, AUXA_R	37, 38	I	Auxiliary A inputs, left and right. AUXA_L and AUXA_R have internal pull-up resistors to CMR. Normally intended for connection to an internal or external CD-ROM analog output.
CMR	39	O	Common mode reference voltage (2.25V±5%). Bypass this pin to analog ground with 47-μF electrolytic in parallel with a 0.1-μF capacitor.
MIC	40	I	Microphone input. MIC has an internal pull-up resistor to CMR.
GNDA	41	I	Analog ground.
CAP3D	42	I	Bypass capacitor to analog ground for 3D effects.
VDDA	43	I	Analog supply voltage (5V±5%). Must be greater than or equal to VDDD –0.3V.
FOUT_R, FOUT_L	44, 45	O	Filter outputs, left and right. AC-coupled externally to CIN_L and CIN_R to remove DC offsets.
CIN_L, CIN_R	46, 47	I	ADC and first channel DAC mixer inputs. These pins have internal 50k pull-up resistors to CMR.
LINE_L, LINE_R	48, 49	I	Line inputs, left and right. LINE_L and LINE_R have internal pull-up resistors to CMR.
AOUT_L, AOUT_R	50, 51	O	Line-level stereo outputs, left and right. These pins can drive a 5k ohm AC load.

Table 1 ES1938 Pin Descriptions (Continued)

Names	Pin Numbers	I/O	Descriptions
PCSPKO	53	O	Analog output of PCSPKI with volume control.
PCSPKI	54	I	Normally low digital PC speaker signal input. This signal is converted to an analog signal with volume control and appears on analog output PCSPKO.
MSO	55	O	MIDI serial data output.
MSI	56	I	MIDI serial input. Schmitt trigger input with internal pull-up resistor. Either MPU-401 or SoundBlaster formats.
SIRQ	57	I/O	Serialized IRQ. (Optional motherboard implementation.)
NC	58, 59	—	Reserved.
INTAB	60	O	PCI interrupt request.
PCPCIREQB	61	O	PC/PCI serialized DREQ output. (Optional motherboard implementation.)
PCPCIGNTB	62	I	PC/PCI serialized DACK input optional motherboard implementation.
CLKRUNB	63	I/O	PCI clock state for power management.
PRSTB	65	I	PCI reset.
PCLK	66	I	PCI clock. This clock times all PCI transactions.
GNTB	67	I	PCI busmaster grant.
REQB	68	O	PCI busmaster request, tri-state output.
IDSEL	78	I	PCI device select for configuration.
FRAMEB	90	I/O	PCI cycle frame.
IRDYB	91	I/O	PCI initiator ready.
TRDYB	92	I/O	PCI target ready.
DEVSELB	93	I/O	PCI device select.
STOPB	94	I/O	PCI stop transaction.
LOCKB	95	I/O	PCI lock.
PAR	96	I/O	PCI parity.

ORDERING INFORMATION

Part Number	Description	Package
ES1938S	PCI <i>AudioDrive</i>	100-pin LQFP



ESS Technology, Inc.
48401 Fremont Blvd.
Fremont, CA 94538
Tel: (510) 492-1088
Fax: (510) 492-1898



No part of this publication may be reproduced, stored in a retrieval system, transmitted, or translated in any form or by any means, electronic, mechanical, manual, optical, or otherwise, without the prior written permission of ESS Technology, Inc.

ESS Technology, Inc. makes no representations or warranties regarding the content of this document.

All specifications are subject to change without prior notice.

ESS Technology, Inc. assumes no responsibility for any errors contained herein.

(P) U.S. patents pending.

AudioDrive is a registered trademark of ESS Technology, Inc.

ESFM is a trademark of ESS Technology, Inc.

Certain audio features of this product manufactured under a license from Desper Products, Inc., Spatializer and the circle-in-square device are trademarks owned by Desper Products, Inc. U. S. Patent numbers #4,308,423, #4,355,203, #5,412,731.

All other trademarks are owned by their respective holders and are used for identification purposes only.